

Accuphase

MULTICHANNEL CONTROL CENTER

CX-260

- 2-channel/6-channel compatible
- Current feedback principle ensures superb high-range phase characteristics
- 6 totally separate modular line amplifiers
- 6 separate preset level controls
- High-quality six-gang volume control
- Mixdown function
- Logic-controlled relays for shortest signal paths
- Option boards allow digital input





Build the high-end home theater of your dreams — 2-channel/6-channel compatible preamplifier features 6-channel (5.1ch) analog inputs/outputs. Six entirely separate line amplifiers and six preset level controls, high-quality 6-gang volume control. Mixdown function. In two-channel mode, six line amplifiers are connected in triple parallel MCS configuration.

The CX-260/PX-600 is the long-awaited preamplifier/power amplifier combination from Accuphase designed from the ground up for multi-channel surround systems that aim for absolute top quality in picture and in sound. These two products will allow the true audiophile to build a home theater that provides audiovisual enjoyment without making any sacrifices when it comes to sonic accuracy.

Accuphase's extensive experience in the realm of pure audio is in evidence everywhere in the CX-260/PX-600. The no-compromise Accuphase approach is applied here not only to two-channel stereo but also to multi-channel operation that brings the excitement of a concert hall and the thrill of a movie theater right into the living room. The amazingly realistic sound stage that can be created with these components goes far beyond the limitations of conventional surround sound. Music playback in stereo sounds more alive and realistic than ever, and surround sources acquire an additional dimension of scale and natural authority. Discover a new world where sound and image blend to form a home theater environment with true high-end performance.

Control center compatible with 2-channel/6-channel operation

Besides conventional 2-channel stereo, the Control Center CX-260 allows input of a 6-channel (5.1ch) analog signal as supplied for example by a DVD player with digital decoder or other processor. Two input groups named LINE 1 and 2 are provided, with six balanced and six unbalanced connectors each. The six-gang main volume control adjusts all channels in one action, but in addition, six individual level controls are also provided. This is possible because the CX-260 has six separate line amplifier circuits and balanced output stages.

Six discrete line amplifiers designed for optimum sound. MCS configuration in stereo mode further improves sound quality.

The CX-260 has six line amplifiers that employ a

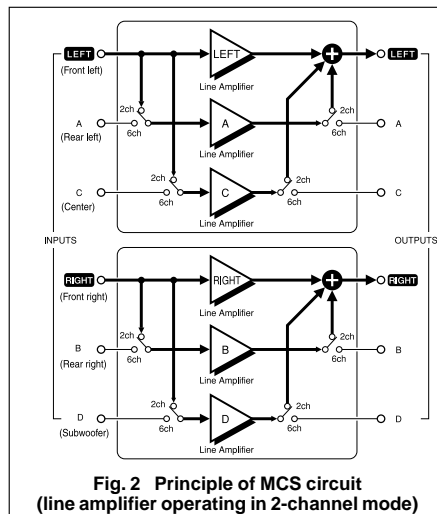
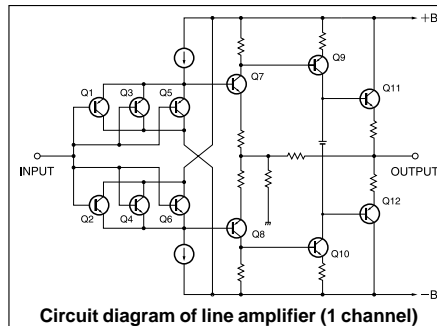

pure complementary push-pull configuration and are built with hand-selected discrete parts. For minimum noise, three input devices are used in parallel.

When the unit is operating in two-channel mode, the six line amplifiers are connected in a triple parallel MCS (Multiple Circuit Summing-up) configuration, as shown in Figure 2. By adding the performance advantages of each circuit, S/N ratio, distortion and other important parameters are

further improved, resulting in a stereo amplifier with even better characteristics.

Current feedback circuit topology prevents phase shifts

The CX-260 uses the signal current rather than the more conventionally used voltage for feedback. The impedance at the current feedback point is kept very low, which means that there is almost no phase shift. Phase compensation via negative

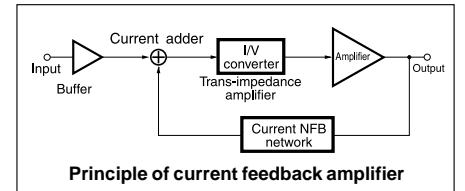

feedback can therefore be kept to a minimum, resulting in excellent transient response and superb sonic transparency.

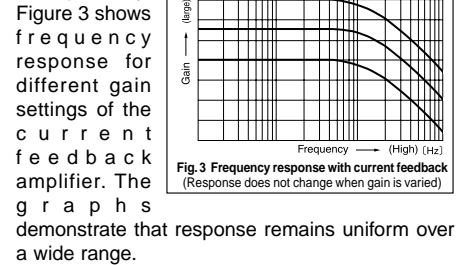

Modular construction and separate power transformers for left and right channel

The line amplifiers and balanced output amplifiers of the six channels are housed in separate modules. Including other units such as unbalanced input stages and mixdown circuitry, the CX-260 has a total of 16 modules neatly arranged on a motherboard. On the power supply side, entirely separate transformers and filtering capacitors for



* Do not stack the CX-260 and PX-600.

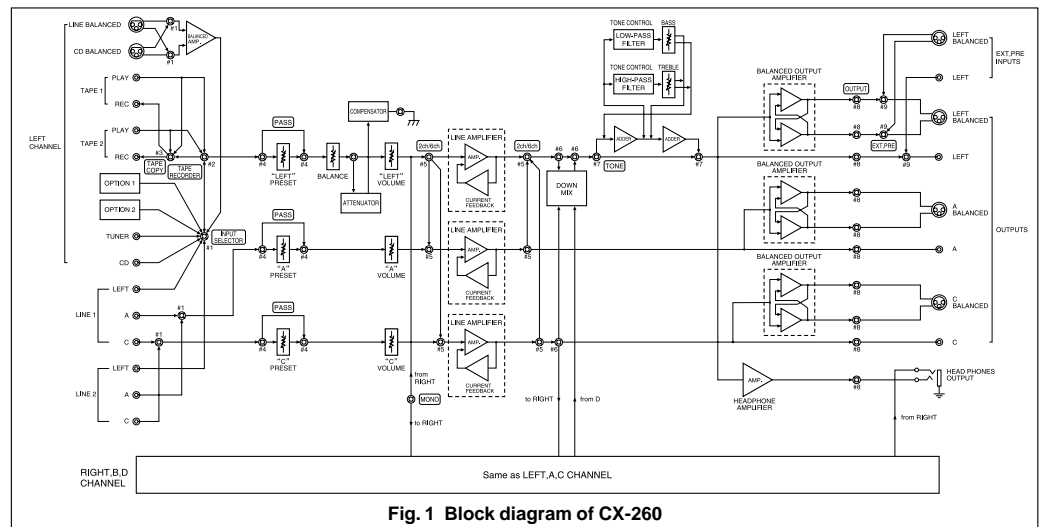

the left and right channel result in a true twin-mono design. A wide-band, low-impedance power supply circuit is integrated in each modular unit, to thoroughly prevent the possibility of unwanted interaction between amplifier stages.

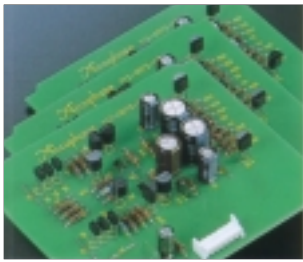

Mixdown function allows 4-channel playback of 6-channel sources

A special function called "mixdown" lets you

combine the six channels of a 5.1ch source into four channels for playback. As shown in Figure 4, the center channel and subwoofer signals of the

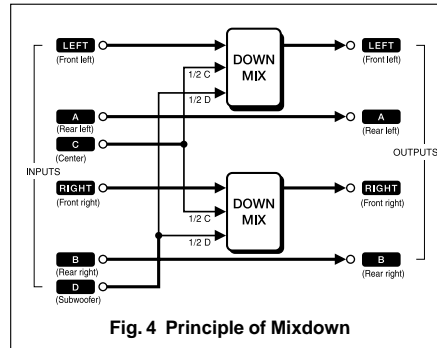

Fig. 4 Principle of Mixdown

six-channel source are mixed into the left and right front channels, resulting in a 4-channel arrangement with two front and two rear channels. This is useful for example when the placement of the monitor or screen makes it difficult to position a center speaker, or when the design of the room is not suitable for a subwoofer. Thanks to the mixdown function, you can still enjoy 5.1ch surround program sources in such cases.

Individual level controls for all channels

Separate controls for each of the six channels make it easy to fine-adjust the balance between speakers.

- Control turned fully clockwise (max.) : 0 dB
- Center click-stop : -6 dB
- Control turned fully counterclockwise (min.) : -∞

Once the levels for the channels have been preset, the master volume control that operates on all six channels together can be used to adjust the listening volume. It is also possible to bypass the preset controls altogether simply by pushing a switch. In 2-channel mode, the controls are bypassed by default.

Using an external preamplifier for stereo playback

For users who wish to dedicate another preamplifier to pure audio playback, the EXT PRE button provides an easy solution. This is also the operation default when power to the CX-260 is off.

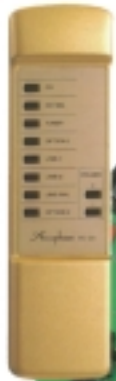

- Supplied remote commander RC-20 allows volume adjustment and program source selection

- Line amplifiers, mixdown circuit, balanced input/output amplifiers and other modules neatly arranged on PCB motherboard (total 16 modules)



- Hermetically sealed relays directly connected to gold-plated input/output connectors

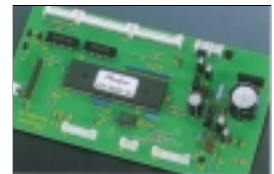

- Assembly for Logic control



- High-reliability, high-quality parts



Other features and functions

- Supplied remote commander allows volume adjustment and source selection
- Dedicated headphone amplifier for optimum sound
- Tone controls with summing active filters for pure sound
- Balanced output circuitry with bridged feedback
- Logic-controlled relays for program source switching ensure pure sound and long service life
- High-quality six-gang volume control

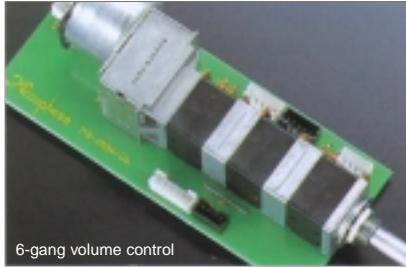

6-gang volume control

Option Boards

Three kinds of options boards are available which can be installed in rear-panel slots.

- All option board inputs are for 2-channel playback.
- The DAC-10 cannot be used in the models E-407, E-406V, E-306V, E-211 and C-265.
- The Analog Disc Input Board AD-9 and the Line Input Board LINE-9 can also be used.

Option board shown in photo is DAC-10



Digital Input Board DAC-10

MDS (Multi Delta Sigma) D/A converter. Coaxial and optical fiber inputs. High-quality reproduction of digital music signal from CD/DVD player, DAT, MD (sampling frequency 32 - 96 kHz, 24 bits).

Analog Disc Input Board AD-10

High-performance, high-gain equalizer for faithful playback of analog records. Internal DIP switches allow MM/MC selection, MC input impedance selection, and subsonic filter on/off switching.

MM	Gain: 36 dB Input impedance: 47 kilohms
MC	Gain: 62 dB Input impedance: 10/30/100 ohms, switchable

Line Input Board LINE-10

This option board provides an additional set of conventional line inputs which can be used to connect a CD player, tuner, or other component with analog output.

FRONT PANEL

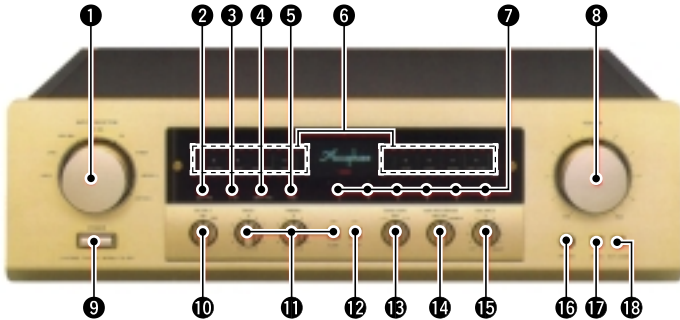

REAR PANEL

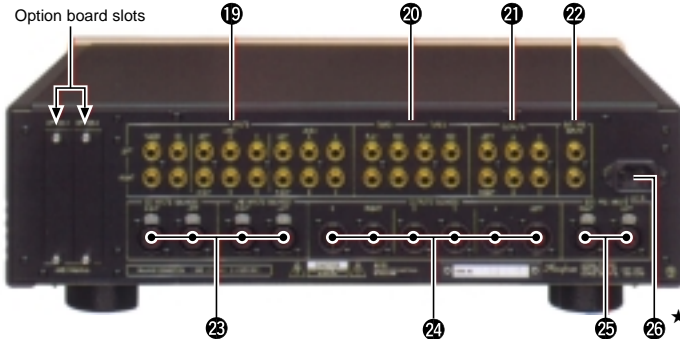

- | | |
|--|--|
| 1 Input selector | 18 Attenuator |
| 2 External preamplifier selector button | 19 Line inputs (LINE 1 and 2 are 6-channel inputs) |
| 3 2ch/6ch selector button | 20 Tape recorder record/play connectors |
| 4 Mixdown on/off button | 21 Unbalanced output connectors (6 channels) |
| 5 Preset level control bypass button | 22 External preamplifier inputs (unbalanced) |
| 6 Function LED indicators | 23 CD/LINE balanced input connectors |
| 7 Channel preset level controls | 24 Balanced output connectors (6 channels) |
| 8 Volume control | 25 External preamplifier inputs (balanced) |
| 9 Power switch | 26 AC power supply connector* |
| 10 Output on/off switch | |
| 11 Bass/treble control, TONE ON/OFF button | |
| 12 Compensator on/off button | |
| 13 Tape copy switch | |
| 14 Tape recorder switch | |
| 15 Balance control | |
| 16 Headphone jack | |
| 17 Stereo/mono selector | |

Remarks

- ★ This product is available in versions for 120/230 V AC. Make sure that the voltage shown on the rear panel matches the AC line voltage in your area.
- ★ The shape of the AC inlet, and plug of the supplied power cord depends on the voltage rating and destination country.

CX-260 Guaranteed Specifications

Guaranteed specifications are measured according to EIA standard RS-490.

- **Frequency Response** BALANCED/UNBALANCED INPUT
3 - 300,000 Hz +0 -3.0 dB
20 - 20,000 Hz +0 -0.2 dB
- **Total Harmonic Distortion** (for all inputs) 0.005%
- **Input Sensitivity, Input Impedance**

Input	Sensitivity		Input impedance
	For rated output	For 0.5 V output	
BALANCED	252 mV	63 mV	40 k Ω
UNBALANCED	252 mV	63 mV	10 k Ω
- **Rated Output, Output Impedance**

Input	Output	Impedance
BALANCED/UNBALANCED OUTPUT	2 V	50 ohms
TAPE REC	252 mV	200 ohms
- **Signal-to-Noise Ratio**

Input	Input shorted, IHF-A weighting		Residual noise
	EIA S/N	S/N ratio at rated input	
BALANCED	106 dB	96 dB	1.2 μV
UNBALANCED (2ch)	120 dB	96 dB	1.2 μV
UNBALANCED (6ch)	119 dB	95.5 dB	1.7 μV
- **Maximum Output Level** (0.005% THD, 20 - 20,000 Hz)
BALANCED/UNBALANCED OUTPUT: 5.0 V
TAPE REC: 5.0 V
- **Maximum Load Impedance** BALANCED/UNBALANCED OUTPUT: 600 Ω
TAPE REC: 10 kΩ
- **Gain** BALANCED/UNBALANCED INPUT → BALANCED/UNBALANCED OUTPUT: 18 dB
BALANCED/UNBALANCED INPUT → REC OUTPUT: 0 dB
- **Loudness Compensation** +6 dB (100 Hz)
- **Tone Controls** Turnover frequency and adjustment range
BASS: 300 Hz ±10 dB (50 Hz)
TREBLE: 3 kHz ±10 dB (20 kHz)
- **Attenuator** -20 dB
- **Headphones Jack** Suitable impedance: 4 - 100 ohms
- **Power Requirements** AC120 V/230 V (Voltage as indicated on rear panel), 50/60 Hz
- **Power Consumption** 25 watts
- **Maximum Dimensions** Width 475 mm (18-11/16")
Height 150 mm (5-7/8")
Depth 405 mm (15-15/16")
- **Weight** 17.5 kg (38.6 lbs) net
22.0 kg (48.5 lbs) in shipping carton
- **Supplied Remote Commander RC-20**
Remote control principle: Infrared pulse
Power supply: 3 V DC (IEC R6 batteries × 2)
Maximum dimensions: 55 mm (2-3/16") (width)
194 mm (11/16") (height)
18 mm (7-5/8") (depth)
Weight: 100 g (including batteries)

2-channel (stereo) playback

Except for LINE 1 and 2, all inputs are 2-channel inputs, so no special steps are necessary. For LINE 1 or 2, connect the source to the LEFT and RIGHT connectors and set the 6-CH button to OFF (LED out).

- The input from any option board installed in slot OPTION 1 or 2 also is handled in 2-channel mode.
- The mixdown (DOWN MIX) and PASS functions cannot be used.
- All preset level controls are bypassed.

Supplied accessories: • Power cord
• Audio cable with plugs L-10G (1 set)
• Remote commander RC-20

6-channel (5.1ch) playback

Set the input selector to LINE 1 or LINE 2, and set the 6-CH button to ON (LED lit).

- The following functions (11 - 18) operate only on the Left/Right channel:
TONE, COMP, TAPE COPY, TAPE RECORDER, BALANCE, PHONES, MONO, ATT
- When using an active subwoofer with built-in power amplifier, directly connect the "D" output of the CX-260 to the input of the subwoofer, using an audio cable with plugs.